

# High Precision Motorized Linear Stages – 0.4µm



Up To 400mm Travel, Integrated Controller: USB/RS232, and Manual Knob, XYZ

## DATASHEET

[Return to the Webpage](#)



### Features

- All-In-One Construction
- USB Controller Integrated
- Ease Use GUI
- Power Supplier/Cable Included
- Manual Control Built-In
- XYZ Configurable
- Optical Encoder/Position Calibrators
- High Precision/Repeatability

### Applications

- Optical Systems
- Mechanical Systems
- Lab Use
- Instruments

The ILSM series motorized stages feature an innovative design that combines sub-micron precision with ease of use and affordability, offering a convenient solution for programmable motion. The dual ball-bearing and lead screw stage features a proprietary optical moving encoder for constant step calibration, and two position sensors at each end for resetting and calibration. Each stage has a built-in smart motor driver having computer interfaces via USB/RS232 cable. Additionally, a manual control knob is built into the system: pressing it switches to manual mode; rotating it initiates motion; turning it further increases the speed; and turning it past the center reverses the direction of movement. Ethernet control is also available with an additional control box. The system comes with a wall-pluggable power supply and a user-friendly GUI that can be downloaded. A command list is provided to help customers write their own code.

The unit has a center mounting plate that is compatible with optical components and stages End plate is available for creating optical setups or instruments. Multiple ILSM stages can be interconnected using the provided cables, allowing for single USB/RS232 GUI interface control. This setup enables the configuration of XYZ stages using various ILSM stage combinations. Associated mounting kits are available for purchase. The highest precision is achieved when moving in a single direction. Mounting plates

### Specifications

Parameter	Min	Typical	Max	Unit
Travel Range	0	100	1500	mm
Accuracy	0.2	0.4	0.5	µm
Repeatability	0.4			µm
Incremental Move	10			nm
Acceleration			34	m/s <sup>2</sup>
Speed	0.00001		100	mm/s
Encoder Count	5			nm
Operating Temperature	0		50	°C
Continuous Thrust	-40		35	N
Pulse Thrust			50	N
Center Load		250	750	N
Moving Mass			1.8	kg
Maximum Horizontal Load			7	kg
Manual Control	Push Switch	Indexed Knob		
Auto Control Interface		USB/RS232		
XYZ Interface <sup>[1]</sup>		USB/RS232		
Power Supply (included)		12VDC/3A		

#### Notes:

[1]. Up to 3 Agiltron stages can be linked and controlled via a single USB/GUI. XYX forming brackets are available to be purchased.

**Note:** The specifications provided are for general applications with a cost-effective approach. If you need to narrow or expand the tolerance, coverage, limit, or qualifications, please [click this link](#):

**Legal notices:** All product information is believed to be accurate and is subject to change without notice. Information contained herein shall legally bind Agiltron only if it is specifically incorporated into the terms and conditions of a sales agreement. Some specific combinations of options may not be available. The user assumes all risks and liability whatsoever in connection with the use of a product or its application.

Rev 12/23/24

# High Precision Motorized Linear Stages – 0.4 $\mu$ m



Up To 400mm Travel, Integrated Controller: USB/RS232, and Manual Knob, XYZ

## DATASHEET

### Configuration

■ X

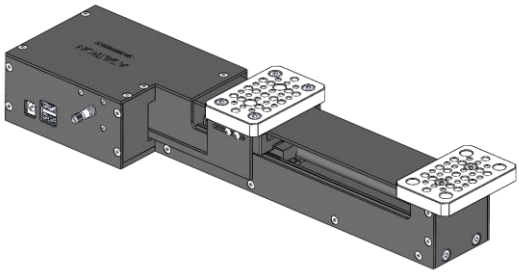

■ XY

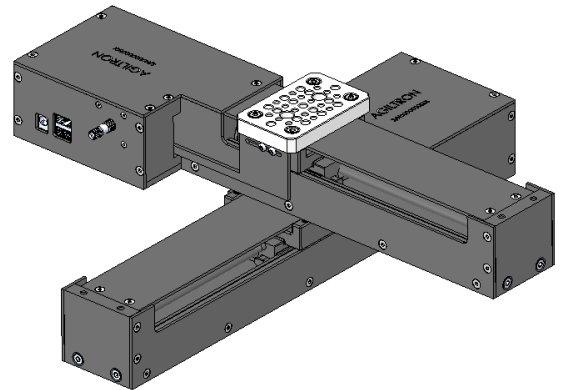

■ XZ

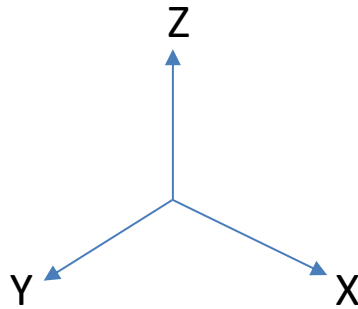
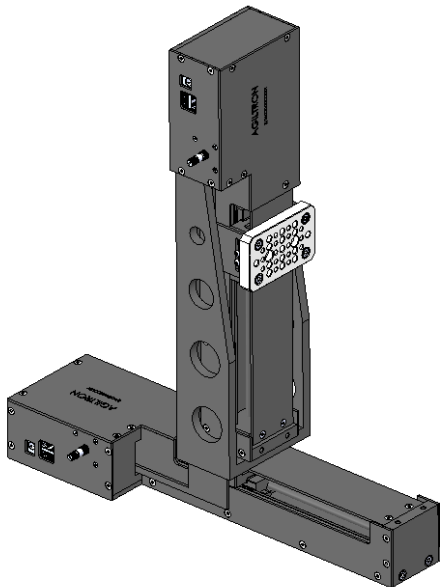

■ XYZ

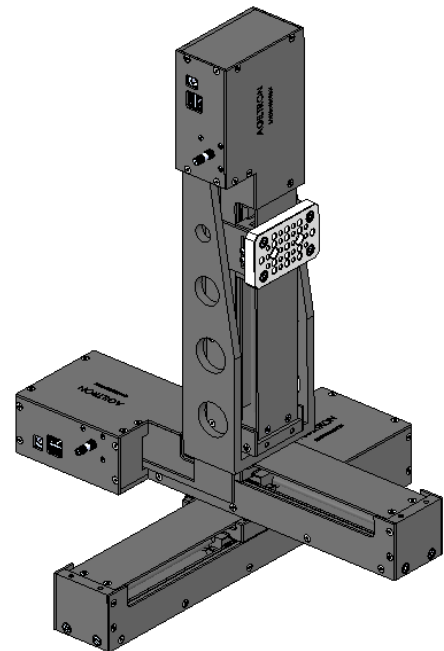

# High Precision Motorized Linear Stages – 0.4μm



Up To 400mm Travel, Integrated Controller: USB/RS232, and Manual Knob, XYZ

## DATASHEET

### Mechanical Dimensions (mm)

■ X

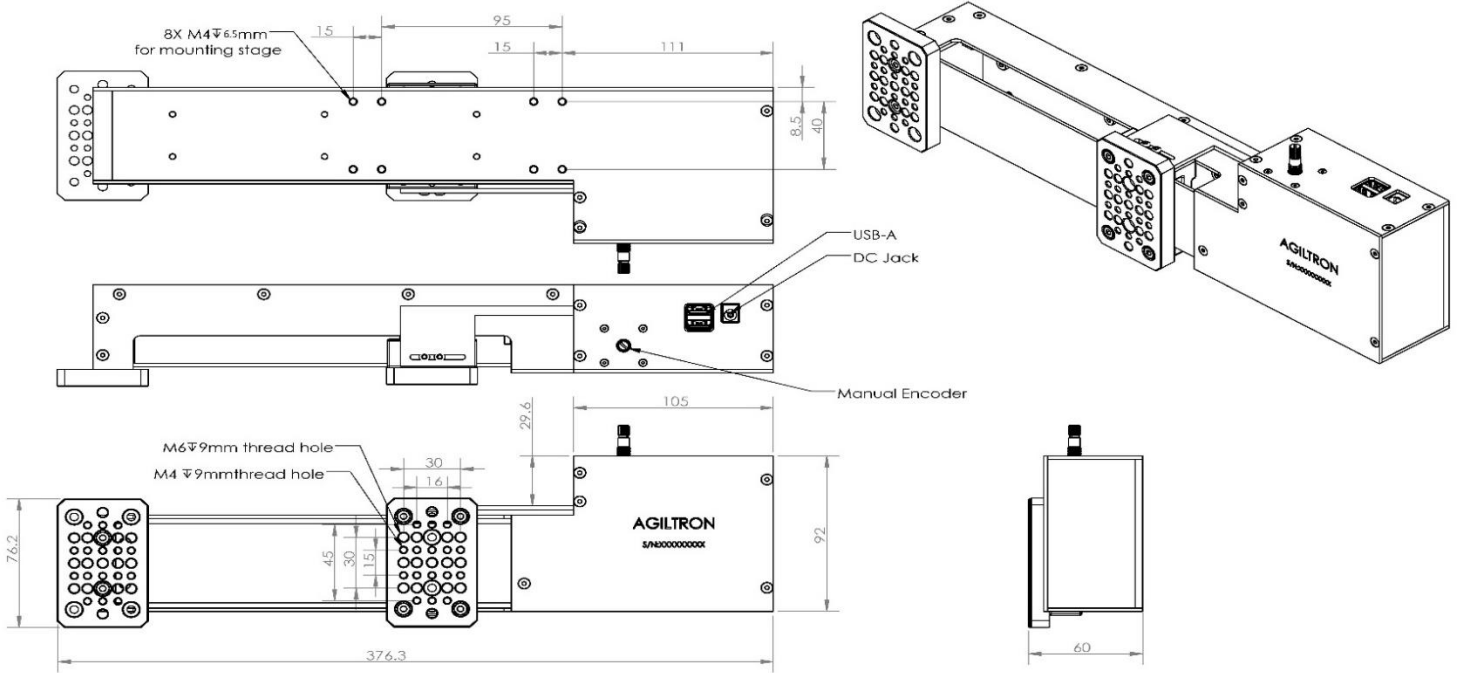

■ XZ Stage > 120 mm movement

# High Precision Motorized Linear Stages – 0.4μm

Up To 400mm Travel, Integrated Controller: USB/RS232, and Manual Knob, XYZ



## DATASHEET

### Operation Instruction

- Plug in the provided power supply.
- Pull and rotate the side knob to operate the motor manually.
- Connect the device to a computer using the provided USB cable.
- Load the GUI from the provided memory stick or download it from our website.
- Run the GUI.
- If you encounter any issues, please email us at sales@photonwares.com.

### Ordering Information

Prefix	Type	Travel	Precision	Package	Moving *	Bracket	End Optic Plate **	Ethernet Control Box
ILSM-		120 mm = 1 220 mm = 2 80 mm = 8 300 mm = 3 400 mm = 4 Special = 0	Regular = 1 Special = 0	Regular = 1 Special = 0	X = 1 XY = 2 XYZ (80mm) = 3 XYZ (120mm) = 4 Special = 0	Non = 1 Y = 2 Z = 3 Two parallel X = 4 Special = 0	Non = 1 Yes = 2 Special = 0	Non = 1 Yes = 2

**Notes:**

- \* For movements less than 120nm, two X-axis stages are cross-stacked on top of each other to form XY. For movements greater than 120nm, two X-axis stages are positioned at the bottom, with one cross-stacked X stage on top to form XY stage with enhanced stability.
- \*\* The End Optic Plate is designed to mount optical components, as illustrated in the X-stage drawing.

Red is special order that takes longer time to deliver

- Y Bracket: Forms an XY stage – \$195.
- Z Bracket: Creates an XZ stage or an XYZ stage when combined with the Y Bracket – \$325.
- Ethernet Control Box: Enables remote control of the XYZ stage – \$890.