

# NanoSpeed™ Premium 1x1, 1x2, 2X2 Fiber Optical Switch



(50ns rise/fall, 800kHz, up to 20W, bidirectional)

DATASHEET

[Return to the Webpage](#)



## Features

- Solid-State
- High speed
- Ultra-high reliability
- Low insertion loss
- Compact

## Applications

- Optical blocking
- Configurable operation
- Instrumentation

The NS Premium Series fiber optic switch is developed for fast rise/fall and high repeat rate based on a cost-effective electro-optical technology. This is achieved using patented electro-optical configuration featuring clean fast response without ripples and temperature compensation for outdoor operation. The switch is intrinsically bidirectional and selectable for polarization-independent or polarization-maintain by the fiber type.

The NSP fiber optic switch is designed to meet the most demanding switching requirements of continuous operations over 25 years and non-mechanical ultra-high reliability. The NSP Series switch is mounted on a specially designed PCB driver with 0-5V TTL trigger signals.

The rise/fall time is intrinsically related to the crystal properties, and the repetition rate is associated with the driver. There are poor frequency response sections due to the device resonances. The NS devices are shipped mounted on a tuned driver.

The NS series switches respond to a control signal with any arbitrary timing with frequency from DC up to MHz. The switch is usually mounted on a tuned driver prior to shipping. The electrical power consumption is related to the repetition rate the switch is operated.

The dual-stage configuration increases the extinction ratio or cross-talk value.

## Specifications

Parameter		Min	Typical	Max	Unit
Insertion Loss <sup>[1]</sup>	1900-2200nm <sup>[2]</sup>		0.8	1.5	dB
	1700~2300nm		0.8	1.8	
	1260~1650nm		0.6	1.0	
	850~1100nm		1.2	1.5	
	780-850nm <sup>[2]</sup>	1.2	1.5	2.2	
Cross Talk On/Off Ratio <sup>[3]</sup>		18	25	30	dB
Durability		10 <sup>14</sup>			cycles
PDL (SMF Switch only)			0.15	0.3	dB
PMD (SMF Switch only)			0.1	0.3	ps
ER (PMF Switch only)		18	25		dB
IL Temperature Dependency			0.25	0.5	dB
Return Loss		45	50	60	dB
Optical Rise/Fall Time <sup>[4]</sup>			50	60	ns
Repetition Rate	Dual Stage	DC		0.4	MHz
	Single Stage	DC		0.8	
Optic Power Handling <sup>[5]</sup>	Normal power version		0.3	0.5	W
	High power version		5	20	W
Operating Temperature range		-5		75	°C
Storage Temperature		-40		100	°C

### Notes:

- [1]. For 1x1 only, 1x2 adds 0.3dB, 2x2 adds 0.5 dB. Measured without connectors. Each connector adds 0.3dB.
- [2]. Wavelengths < 850nm or > 1900nm will be implemented in the special version.
- [3]. ±25nm, Cross talk is measured at 100kHz, which may be degraded at the higher repeat rate.
- [4]. It is defined as the rising or fall time between 10% and 90% of optical intensities.
- [5]. Defined at 1310nm/1550nm. The power handling is related to fiber core size, for the shorter wavelength, the handling power is reduced. A proximation curve is provide in the following page. We offer core expansion to increase the power handling.

**Note:** The specifications provided are for general applications with a cost-effective approach. If you need to narrow or expand the tolerance, coverage, limit, or qualifications, please [\[click this link\]](#):

**Warning:** This is an OEM module designed for system integration. Do not touch the PCB by hand. The electrical static damages the chips even without electrical power on. Unpleasant electrical shock may also be felt. Do not put the PCB on a conducting surface. For laboratory use, please buy a Turnkey system that is housed inside a metal protection box with connections on the panels.

**Legal notices:** All product information is believed to be accurate and is subject to change without notice. Information contained herein shall legally bind Agiltron only if it is specifically incorporated into the terms and conditions of a sales agreement. Some specific combinations of options may not be available. The user assumes all risks and liability whatsoever in connection with the use of a product or its application.

Rev 07/29/25

© Photonwares Corporation

☎ +1 781-935-1200

✉ [sales@photonwares.com](mailto:sales@photonwares.com)

🌐 [www.agiltron.com](http://www.agiltron.com)

Information contained herein is deemed to be reliable and accurate as of the issue date. Photonwares reserves the right to change the design or specifications at any time without notice. Agiltron is a registered trademark of Photonwares Corporation in the U.S. and other countries.

# NanoSpeed™ Premium 1x1, 1x2, 2X2 Fiber Optical Switch



(50ns rise/fall, 800kHz, up to 20W, bidirectional)

## DATASHEET

### Mechanical Dimensions (Unit: mm) -

- Device Package K (single stage 1x1, 1x2 and 2x2)

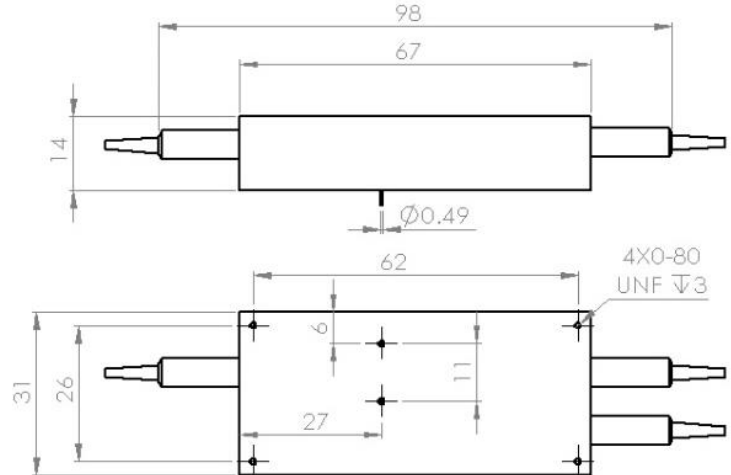

- Device Mounted on 800KHz Driver

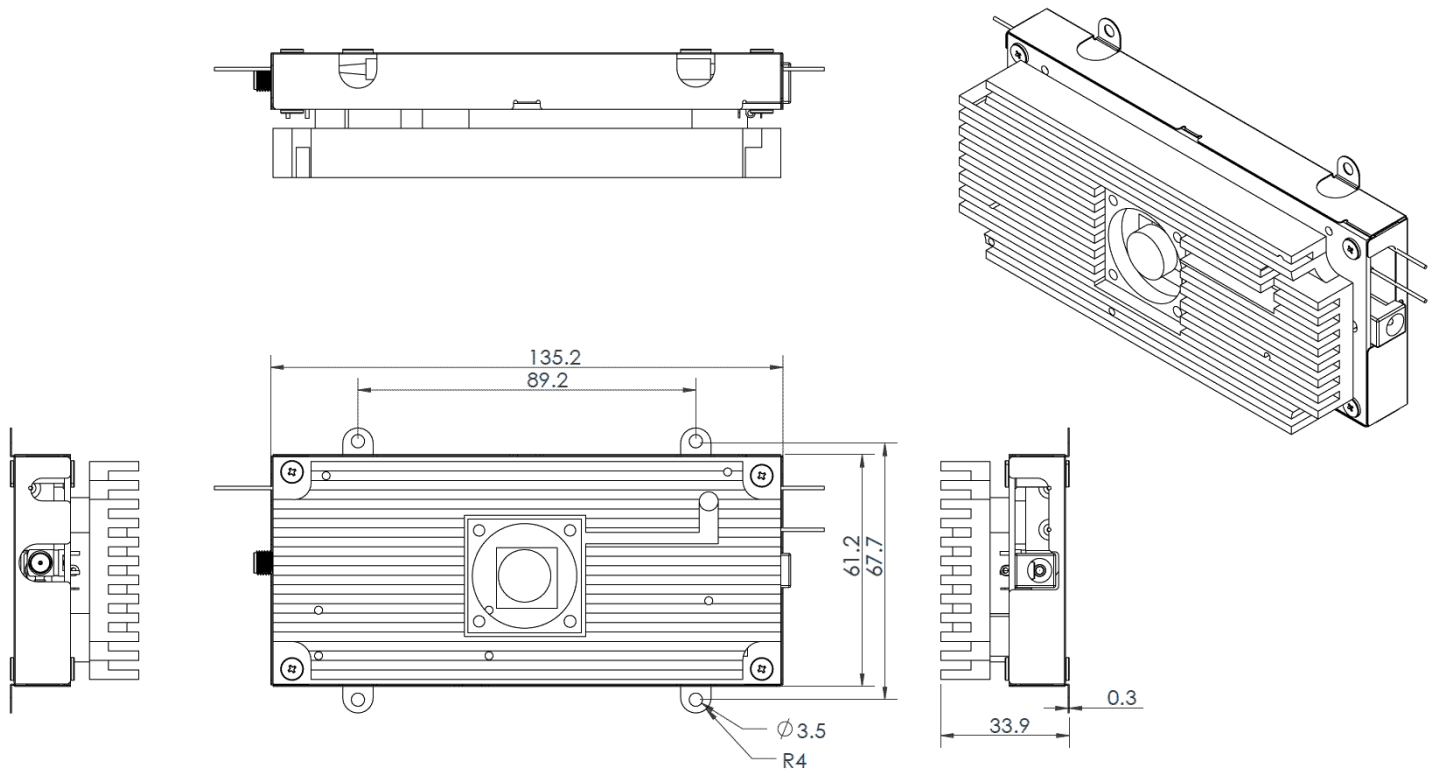

\*Product dimensions may change without notice. This is sometimes required for non-standard specifications.

# NanoSpeed™ Premium 1x1, 1x2, 2X2 Fiber Optical Switch



(50ns rise/fall, 800kHz, up to 20W, bidirectional)

## DATASHEET

### Typical Rise/Fall Response

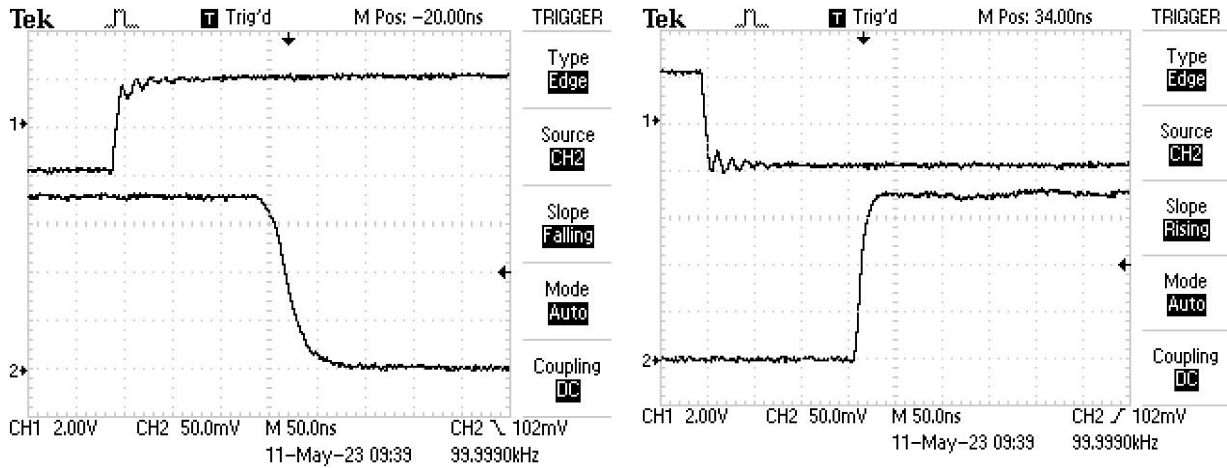

Note: Top Traces are electrical; Bottom traces are optical

### Typical Speed and Repetition Measurement

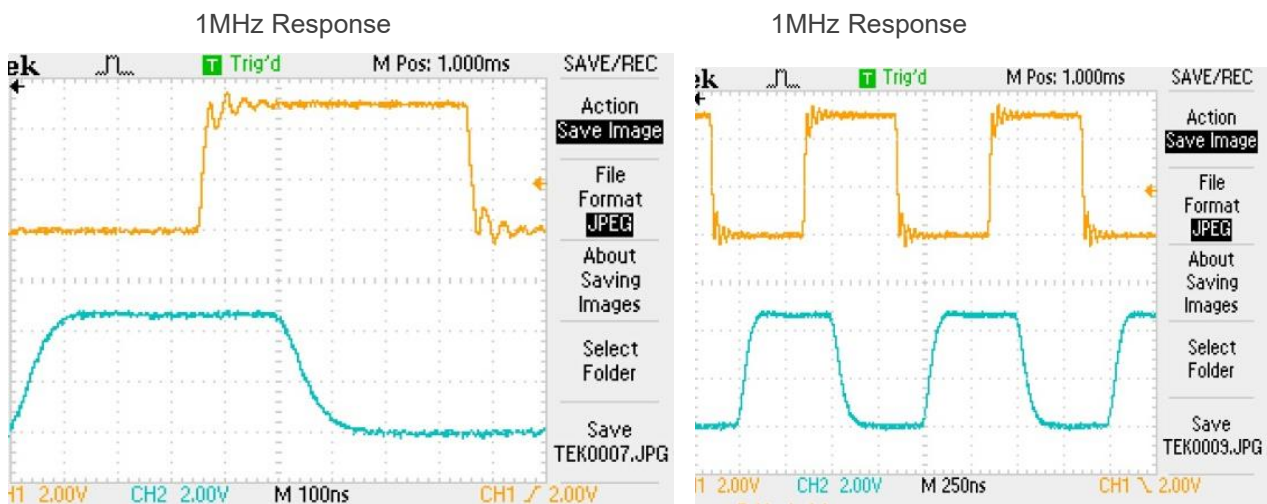

Note: Top Traces are electrical; Bottom traces are optical

# NanoSpeed™ Premium 1x1, 1x2, 2X2 Fiber Optical Switch



(50ns rise/fall, 800kHz, up to 20W, bidirectional)

## DATASHEET

### Optical Path Driving Table

1x1 Optical Path	TTL Signal
ON for normally-open, OFF for normally-close	L (= 0V)
OFF for normally-open, ON for normally-close	H (> 3.5V)

1x2 Optical Path	TTL Signal
Port 1 → Port 2	L (=0V)
Port 1 → Port 3	H (> 3.5V)

2x2 Optical Path	TTL Signal
Port 1 → Port 3, Port 2 → Port 4	L (= 0V)
Port 1 → Port 4, Port 2 → Port 3	H (> 3.5V)

It has an SMA connector for TTL input.

It comes with a 12V wall-pluggable power supply.

### Assembled with Driving Board

The NP switches have driver choices:

Maximum Repetition Rate	Part Number (P/N)
100 kHz	NPSW50ns100kHzD
500 kHz	NPSW50ns500kHzD
800 kHz	NPSW50ns800kHzD

\*Product dimensions may change without notice. This is sometimes required for non-standard specifications.

# NanoSpeed™ Premium 1x1, 1x2, 2X2 Fiber Optical Switch



(50ns rise/fall, 800kHz, up to 20W, bidirectional)

## DATASHEET

### Typical Bandwidth Measurement

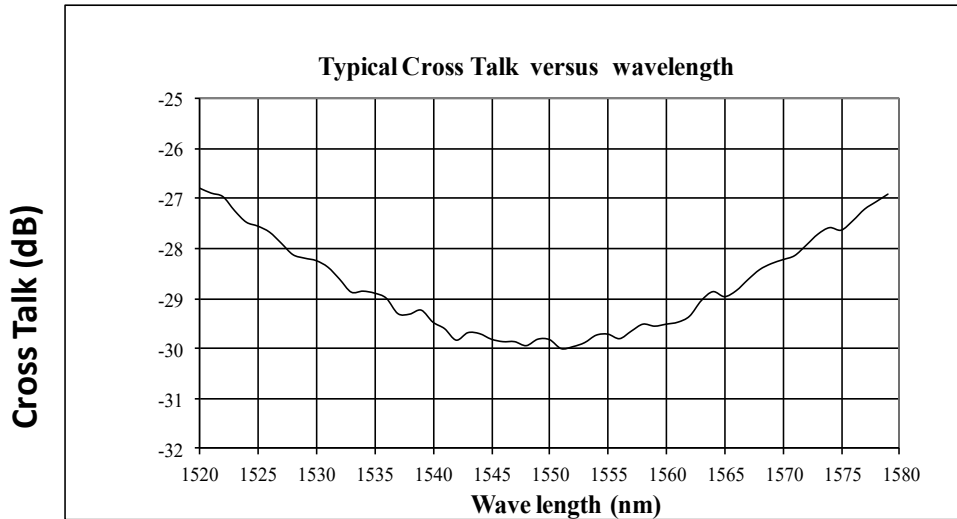

### Optical Power Handling vs Wavelength For Single-Mode Fibers

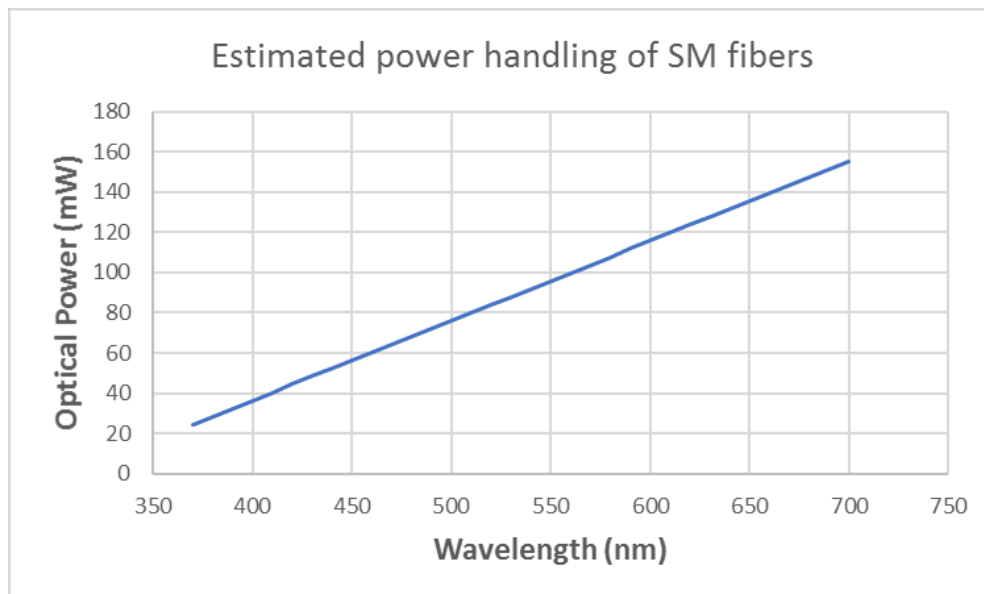

# NanoSpeed™ Premium 1x1, 1x2, 2X2 Fiber Optical Switch



(50ns rise/fall, 800kHz, up to 20W, bidirectional)

## DATASHEET

### Ordering Information

Prefix	Type <sup>[1]</sup>	Wavelength <sup>[2]</sup>	On/Off Ratio <sup>[3]</sup>	Driver	Fiber Type	Fiber Cover	Fiber Length	Connector <sup>[4]</sup>	Optical Power <sup>[5]</sup>	Benchtop
NPNS-	1x1 Transparent =1T 1x1 Opaque =1O 1x2 = 12 2x2 = 22	1060 = 1 <b>2000 = 2</b> 1310 = 3 1550 = 5 1625 = 6 1750 = A 850 = 8 <b>780 = 7</b> <b>650 = E</b> <b>550 = F</b> <b>450 = G</b> Special = 0	18dB (single stage) = 1 30dB (dual stage) <sup>[6]</sup> = 2	None = 2 100kHz = 1 500kHz = 5 800kHz = 8	SMF-28 = 1 Hi1060 = 2 <b>Hi780 = 3</b> PM1550 = 5 <b>SM600 = 6</b> <b>SM800 = 8</b> <b>PM850 = A</b> <b>PM780 = B</b> <b>PM630 = C</b> PM980 = 9 Special = 0	0.9mm tube =3 Bare fiber = 1 Special = 0	0.25m = 1 0.5m = 2 1.0 m = 3 Special = 0	None = 1 FC/PC = 2 FC/APC = 3 SC/PC = 4 SC/APC = 5 ST/PC = 6 LC/PC = 7 LC/APC = A E2000 APC = 9 LC/UPC = U Special = 0	Regular = R 1W = 1 2W = 2 3W = 3 5W = 5 10W = A 15W = C 20W = D	None = 1 Benchtop = B

[1]. Transparent means light transmission is the highest without electrical activation, while Opaques means the transition is at the lowest.

[2]. **Red Color marked** is special order. For operating wavelength beyond stated range, special order can be made with specific coatings. Short Wavelength Bands have lower optical power handling. They use special crystals.

[3]. 30dB (dual-stage) isn't available for 2x2 configuration.

[4]. High-power connectors can ordered as special.

[5]. Only single stage is available for power >1W.

[6]. Dual stage is only available for 1x1

#### Note:

- PM1550** fiber works well for **1310nm**
- Opaque** – light is blocked without applying a voltage
- Transparent** – light goes through without applying a voltage

### Benchtop Box Mechanical Dimension

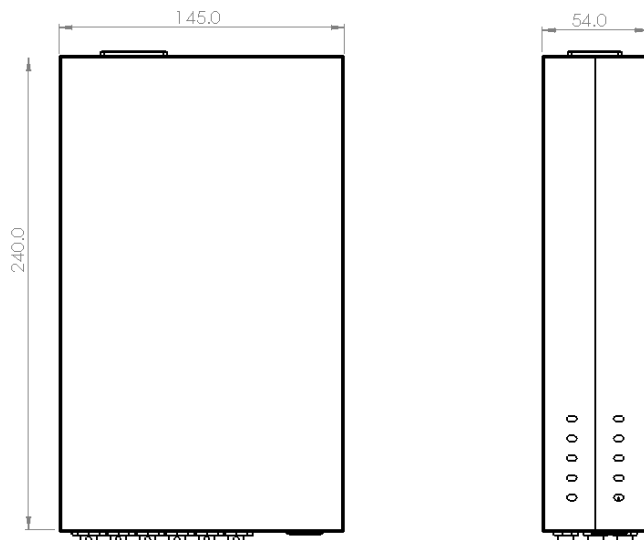

\*Product dimensions may change without notice. This is sometimes required for non-standard specifications.

# NanoSpeed™ Premium 1x1, 1x2, 2X2 Fiber Optical Switch



(50ns rise/fall, 800kHz, up to 20W, bidirectional)

## DATASHEET

### Q & A

**Q:** Can NP device be directly mounted on PCB driver, such as NSDR?

**A:** NO. NP devices can be operated at high frequency up to 1MHz, but the IL and CT are sensitive to the non-uniformity of temperature across device. So, it is highly recommended to separate the NP device with the driver in a platform such as shown in the following example. The delivery of NPSW with driver will be packaged in the 3D printed platform.

The following is one module of NPSW-1x2 & 100kHz of NSDR in a 3D printed platform.

**Q:** Does NP device drift over time and temperature?

**A:** NP devices are based on electro-optical crystal materials that can be influenced to a certain range by the environmental variations. The insertion loss of the device is only affected by the thermal expansion induced miss-alignment. For extended temperature operation, we offer special packaging to -40 -100 °C. The extinction or cross-talk value is affected by many EO material characters, including temperature-dependent birefringence,  $V_p$ , temperature gradient, optical power, at resonance points (electronic). However, the devices are designed to meet the minimum extinction/cross-talk stated on the spec sheets. It is important to avoid a temperature gradient along the device length.

**Q:** What is the actual applying voltage on the device?

**A:** 100 to 300V depending on the version.

**Q:** How does the device work?

**A:** NP devices are not based on Mach-Zander Interference, rather birefringence crystal's nature beam displacement, in which the crystal creates two different paths for beams with different polarization orientations.

**Q:** What is the limitation for faster operation?

**A:** NP devices have been tested to have an optical response of about 300 ps. However, practical implementation limits the response speeds. It is possible to achieve a much faster response when operated at partial extinction value. We also offer resonance devices over 20MHz with low electrical power consumption.

### Operation Manual

1. Connect a control signal to the SMA connector on the PCB.
2. Attach the accompanied power supply (typically a wall-pluggable unit).
3. The device should then function properly.

**Note:** Do not alter device factory settings.

# NanoSpeed™ Premium 1x1, 1x2, 2X2 Fiber Optical Switch

(50ns rise/fall, 800kHz, up to 20W, bidirectional)



DATASHEET

## Application Notes

---

### Fiber Core Alignment

Note that the minimum attenuation for these devices depends on excellent core-to-core alignment when the connectors are mated. This is crucial for shorter wavelengths with smaller fiber core diameters that can increase the loss of many decibels above the specification if they are not perfectly aligned. Different vendors' connectors may not mate well with each other, especially for angled APC.

### Fiber Cleanliness

Fibers with smaller core diameters (<5 μm) must be kept extremely clean, contamination at fiber-fiber interfaces, combined with the high optical power density, can lead to significant optical damage. This type of damage usually requires re-polishing or replacement of the connector.

### Maximum Optical Input Power

Due to their small fiber core diameters for short wavelength and high photon energies, the damage thresholds for device is substantially reduced than the common 1550nm fiber. To avoid damage to the exposed fiber end faces and internal components, the optical input power should never exceed 20 mW for wavelengths shorter 650nm. We produce a special version to increase the handling by expanding the core side at the fiber ends.